

****See box art for wire placement****

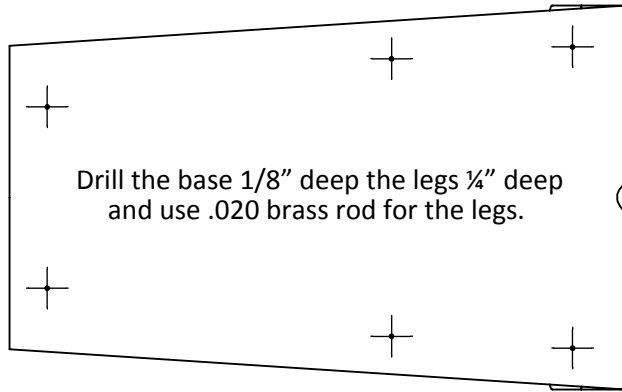

Leg Placement Drill Guide

Lever Location
Cut pins to 1/2"

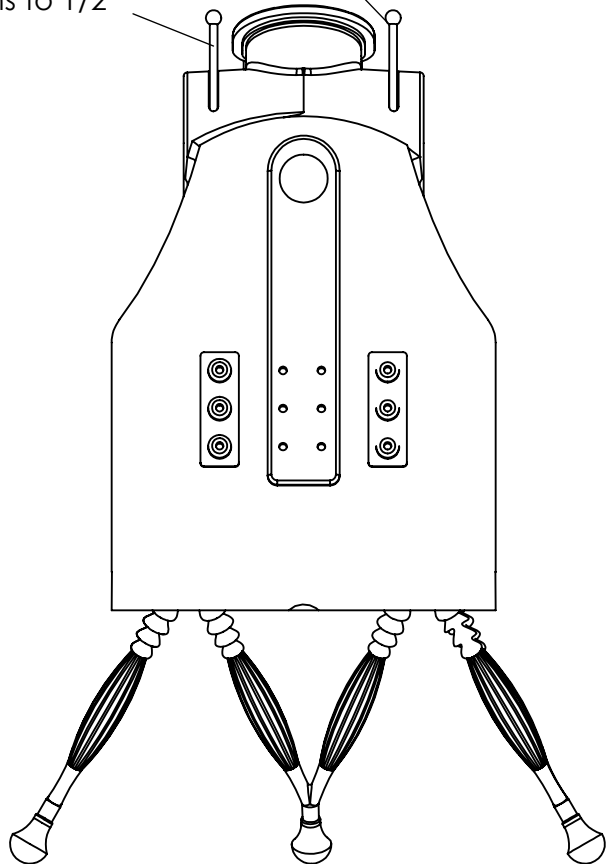

Saddle Location

Tank Location

Vent Location:
Both Sides

Hose Attachment
Landing

Battery Location:
Both Sides

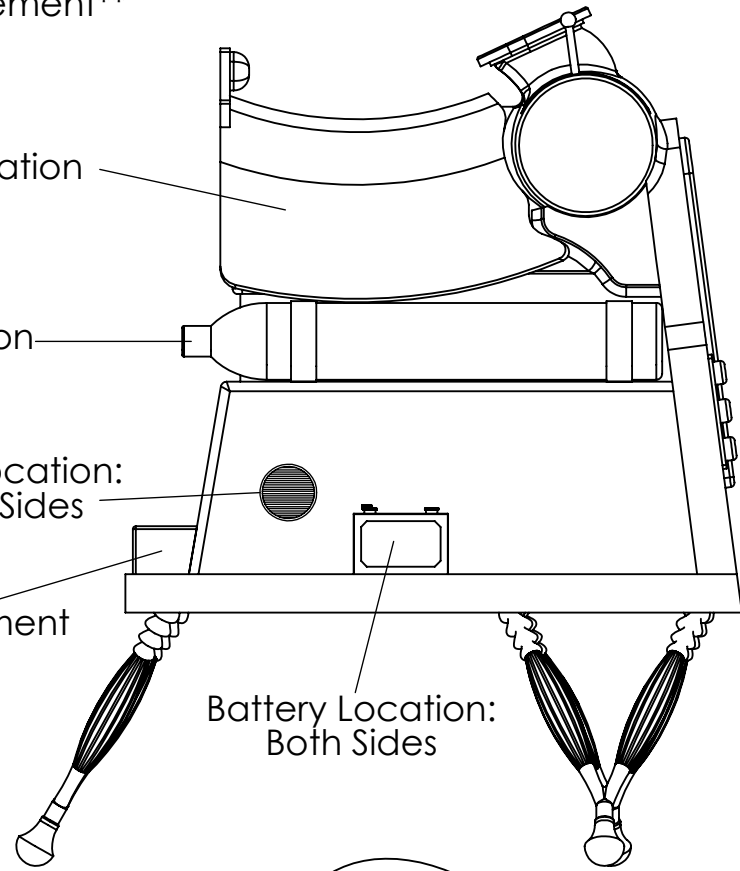

| | |
|---------|-----------------|
| Body | Tan |
| Legs | Green |
| Bellows | Red |
| Rings | White |
| Saddle | Saddle Brown |
| Tanks | Silver w/ black |
| Panel | Green w/ Blue |
| Levers | Silver |
| Battery | Brown |
| Vents | Grey |

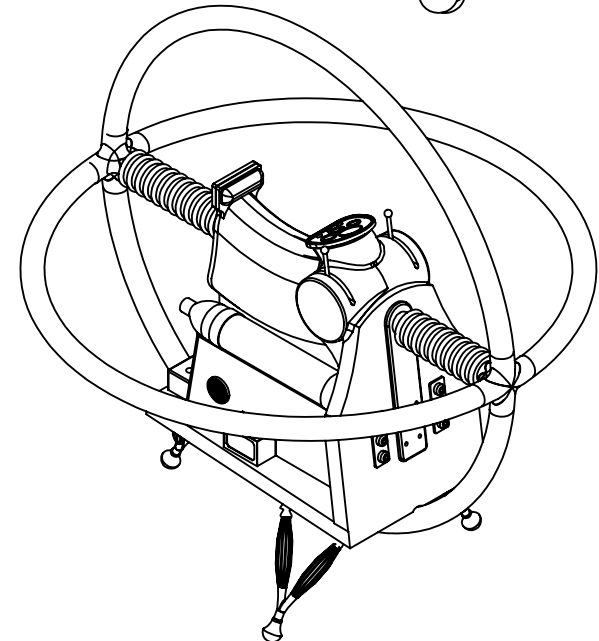

Ring Assembly